

# MIDIjet Pro Wireless MIDI Documentation Revision 2

BY



<b>MIDIJET PRO KIT #002 PACKAGE CONTENTS</b> .....	<b>2</b>
<b>LIMITED WARRANTY</b> .....	<b>3</b>
<b>1. INTRODUCTION</b> .....	<b>4</b>
1.1 DESCRIPTION.....	4
1.2 APPLICATIONS.....	4
1.3 FEATURES .....	4
<b>2. BASIC SETUP AND OPERATION</b> .....	<b>5</b>
<b>3. TIPS AND TRICKS</b> .....	<b>5</b>
<b>4. EXTENDED SETUP</b> .....	<b>6</b>
4.1 CHANNEL SELECTION .....	6
4.2 BINDING MIDI ADAPTERS .....	7
4.3 TROUBLESHOOTING CHECK LIST .....	7
4.4 NOTES ON WIRELESS RANGE .....	8
<b>APPENDIX A: DIP SWITCH CONFIGURATION TABLE</b> .....	<b>9</b>

Copyright © 2004 **Classic Organ Works**

2800 John Street, Unit 4  
Markham, Ontario, Canada  
L3R 0E2

Tel.: (905) 475-1275

Fax.: (905) 475-2735

E-mail: [support@organworks.com](mailto:support@organworks.com)  
WWW: <http://www.organworks.com>

## MIDIjet Pro Kit #002 Package Contents

Quantity	Part Number	Description
1	13-MID-WMJ-002	<b>Wireless MIDIjet Pro kit #002, including:</b>
1	15-MID-WM-002B	Wireless MIDI Adaptor V2 Transmitter BLK 
1	15-MID-WM-002W	Wireless MIDI Adaptor V2 Receiver WHT 
		channel # _____
1	52-DCA-06V500MA	Power Pack 6 VDC 500ma (WMIDI02) 
1	50-BAT-AA-ALK4	Battery Alkaline AA Pkg of 4 
2	65-MID-05DIN6FT	MIDI Cable - 6' long 
1	06-DOC-WMJ-002	Wireless MIDIjet kit #002 Documentation 

# Classic MIDIjet Pro WMJ-002

## LIMITED WARRANTY

Classic Organ Works warrants the MIDIjet Pro to be free from defects in materials and workmanship under normal use for a period of ONE YEAR from the delivery date. This warranty applies only if the product is owned by the original purchaser who has the bill of sale.

This warranty explicitly excludes any cables provided with the MIDIjet, which may become defective as a result of normal wear and tear. The DC power adaptor is included in the warranty however.

In the event of a defect in materials or workmanship, please contact Classic Organ Works immediately. In particular, defects due to shipping should be reported within 15 days for insurance claim purposes. For all other defects, Classic Organ Works agrees to repair or replace all defective parts of said products which are returned, transportation prepaid, for inspection at its service centre within the period of the warranty.

In the event that Classic Organ Works determines the product requires repair because of user misuse or regular wear, it will assess a fair repair or replacement fee. The customer will have the option to pay this fee and have the unit repaired and returned, or not pay this fee and have the unit returned un-repaired.

Classic Organ Works will not be liable for consequential, special, indirect, or similar damages or claims including loss of profit or any other commercial damage, and in no event will Classic Organ Works' liability for any damages to the purchaser or any other person exceed the price paid for the product, regardless of any form of the claim. Classic Organ Works specifically disclaims all other warranties, expressed or implied. Specifically, Classic Organ Works makes no warranty that the product is fit for any particular purpose.

This warranty shall be interpreted, and governed by applicable laws in the province of Ontario, Canada. If any provision of this warranty is found void, invalid or unenforceable, it will not affect the validity of the balance of the warranty, which shall remain valid and enforceable according to its terms. In the event any remedy hereunder is determined to have failed of its essential purpose, all limitations of liability and exclusion of damages set forth herein shall remain in full force and effect.

# **1. INTRODUCTION**



## **1.1 Description**

Eliminate cable troubles! MIDI Works proudly introduces the MIDIjet Pro wireless MIDI adapter. MIDIjet connects any two pieces of MIDI gear. It is designed for live performances or any other situation where laying MIDI cables is undesirable.

Two adapters are included in every kit. As easy to use as standard cables, all that's required is to connect an adapter at both ends of your gear – such as one adapter on a keyboard, the second on a sound module. Up to 31 MIDI connections can be made in the same environment using unique radio channels, selectable via switches. Powered by either 2 'AA' batteries or a DC adapter, it is well suited to both live event and studio environments.

## **1.2 Applications**

MIDIjet is designed to replace standard MIDI cables in situations where cables restrict performer mobility, are visually unpleasant, or awkward to connect.

In live performance environments, MIDIjet liberates a stage floor of MIDI cable clutter. It is also ideal for connecting music equipment in home studios, where hiding cables can be aesthetically important in a multi-purpose room.

## **1.3 Features**

- Up to 500-foot range
- Kit includes all that's required to connect two MIDI devices - two adapters, 4 'AA' alkaline batteries, 2 MIDI cables and one DC power supply included in every box
- Each adapter powered by either DC power supply or 2 'AA' alkaline batteries
- Operate up to 31 adapter pairs at the same time
- Low latency
- 30-hour transmitter battery life
- Operates on 2.4 GHz license-free band
- Gracefully handles signal drop out – no notes stuck on
- Low Battery and Link display indicators
- Measures 2.6" x 1.1" x 4.4" (w x h x d), and weighs 6 oz with batteries



## 2. BASIC SETUP AND OPERATION

### Install Batteries and Connect Power

For each adapter insert 2 ‘AA’ batteries (alkaline required) or connect power supply (6V DC, 500 ma, 2.1 mm connector, positive or negative center) to connector on side of unit.

### Connect MIDI Devices



Instrument's MIDI OUT connected to MIDIjet Transmitter (black box)

MIDIjet Receiver (grey box) connected to MIDI IN

The pair of wireless MIDI adapters replaces a standard MIDI cable. The black unit is the transmitter, and should be connected to the sending instrument's MIDI OUT connector. The grey unit is the receiver, and is connected to the receiving instrument's MIDI IN connector.

### Operation

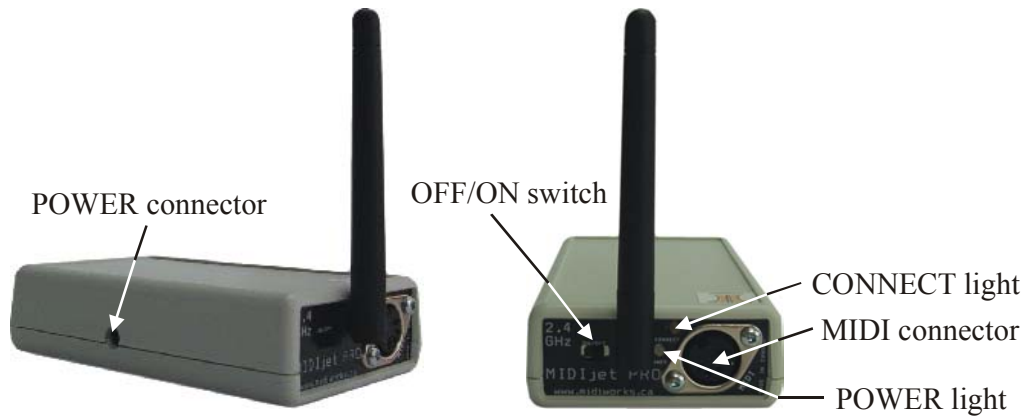

The ‘OFF/ON’ switch controls battery power. In the ‘ON’ position, the adapter is powered only by batteries. In the ‘OFF’ position, the unit will switch to external DC power, if connected, or turn off if not connected. The ‘POWER’ light blinks green to indicate that the unit is functioning. The light changes to red when battery voltage is low.

## 3. TIPS AND TRICKS

- The receiver sends an “All Notes Off” MIDI message if contact is lost with the transmitter. Hence it is possible to turn off hanging (or “stuck on”) notes by turning off the transmitter.
- **Alkaline batteries are required.** On battery power, the transmitter and receiver will run for 30 hours and 10 hours respectively.



- The antenna is mounted on a hinge which allows 90° of movement on a single axis.

## 4. EXTENDED SETUP

Extended Setup is not required for MIDIjet adapters, as they are designed to work as-is out of the box. However, in extreme situations where there is radio interference from other devices, or where there are many MIDIjet units operating in the same environment, the following instructions describe how to assign channels and bind adapter pairs together. Extended setup is performed using DIP switches located beneath the battery door.



Configuration DIP Switches

### 4.1 Channel Selection

Each pair of wireless MIDI adapters operates on 1 of 31 channels. The channel is set at the factory, but it can be changed by the user. Two rules must be followed:

- A Transmit/Receive pair must be:
  - Bound together
  - Set to the same channel
- When using multiple Transmit/Receive pairs, each pair must operate on its own channel

To set the channel:

1. Turn transmitter and receiver OFF.
2. Open the battery door on transmitter and receiver and locate DIP switch.
3. Select a unique channel not currently in use by other MIDIjet Transmit/Receive pairs in your environment. Refer to APPENDIX A: DIP SWITCH CONFIGURATION TABLE for a complete list of switch positions and their corresponding channels. Note that a “1” indicates UP position, and “0” indicates DOWN position.
4. Set the DIP switches on the transmitter and receiver to the selected channel. The switch positions must match.
5. The wireless MIDI system is ready for use.

## **4.2 Binding MIDI Adapters**

Every MIDIjet Pro wireless adapter contains a unique identifier. A transmitter and receiver are “*bound*” together when they acquire their counterpart’s unique identifier. The process of acquiring this information is called “*binding*”. Each pair is bound together at the factory, however, if you happen to have mismatched pairs, it is possible to complete the binding process as follows:

1. Turn transmitter and receiver OFF.
2. Open the battery door on transmitter and receiver and locate DIP switch.
3. Set DIP switches to position 31, “Bind Setup” mode (all switches ON, refer to APPENDIX A: DIP SWITCH CONFIGURATION TABLE).
4. Turn transmitter and receiver ON. The colour of the POWER indicator LED will cycle between green and red.
5. Connect the transmitter and receiver with a standard MIDI cable.
6. The binding process is complete when the POWER indicator LED on the transmitter turns off and its yellow LINK LED turns ON.
7. Switch off both devices. The devices are now bound together and all unique identifier information has been stored.
8. Set both units to the same channel, using a DIP switch position between 1 and 30 inclusively (refer to APPENDIX A: DIP SWITCH CONFIGURATION TABLE).
9. The wireless MIDI system is ready for use.

### **No Binding Mode**

Although the “*bound*” configuration is recommended, two units operate together without the binding process using DIP switch position 0 (refer to APPENDIX A: DIP SWITCH CONFIGURATION TABLE).

## **4.3 Troubleshooting Check List**

1. Check power on Send and Receive units. Power lights should be blinking green. If not, change the batteries or plug in DC power supply.
2. Check that MIDI Out is connected to transmitter (black case) and MIDI In is connected to receiver (grey case)
3. Check for ‘CONNECT’ light. Light should be blinking yellow. If not:
  - a. Set the units next to each other. If the ‘CONNECT’ light starts blinking yellow, you likely are exceeding the range of the unit, another piece of equipment is creating interference, or an object is obstructing the radio signals. See “Notes on Wireless Range”
  - b. If that does not solve the problem, try the units in a difference environment, away from other electronic devices. See “Notes on Wireless Range”
  - c. If that does not solve the problem, ensure the devices are set to the same channel. See extended setup for further details.
    - If the units are set to the same channel and are not connecting, it is possible that the units are not bound together. See the “Binding MIDI Adapters” section.
  - d. If you have multiple pairs (more than two) wireless MIDI adapters, ensure that each pair is operating on its own channel. See extended setup for more details.
  - e. Try operating the units in “No Binding” mode. See the “Binding MIDI Adapters” section.
4. ‘CONNECT’ light is blinking, but MIDI data is not being received.
  - a. Try replacing wireless MIDI adapters with standard cable. If this does not work, the problem lies with the setup of your MIDI system.
  - b. Do you have multiple pairs of Wireless MIDI Adapters? Ensure that you have a matching sender and transmitter, and that each pair is operating on its own channel. See extended setup for further details.
5. Try replacing wireless MIDI adapters with standard cable. If this does not work, the problem lies with the setup of your MIDI system.

## **4.4 Notes on Wireless Range**

Your wireless MIDI Adapter, like your cordless phone, uses radio signals to transmit information. Its wireless range is dependant on the type of obstructions and background radio noise in your environment. There are three general rules for optimizing the range of your wireless MIDI Adapter:

### **1) Avoid obstacles**

Various objects obstruct, absorb, reflect, or diffract radio signals to varying degrees. Obstructions made of metal or water tend to stop the signals, while air, wood, plastic and glass tend to let them pass through without weakening. The number, thickness, and location of obstructions such as walls or ceilings may limit the wireless range of the unit. Position the adapters to minimize the number of walls, ceilings, and other obstructions. Be aware of the direct line between adapters, as a wall that is 1 ft deep appears to be 2 ft thick at a 45 degree angle, and almost 30 ft thick at a 2 degree angle!

### **2) Avoid interference**

Interference is caused by conflicting radio signals emitted by other electrical products, but in particular, microwaves, wireless networking equipment, cell phones, and cordless phones emit signals that can interfere with the operation of the wireless MIDI device. When possible, try to position the wireless MIDI units away from such hostile devices. If the unit is sharing an environment with 2.4 GHz Wi-Fi networks or cordless phones, try changing the channel to avoid interference.

















### **3) Optimize Adapter Orientation**

The MIDIjet Pro adapter features an external antenna. If you are experiencing difficulties, try different antenna orientations. Leave at least 6 inches between the antenna and other objects.



# APPENDIX A: DIP SWITCH CONFIGURATION TABLE







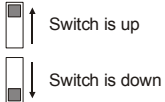







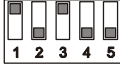

Configuration DIP switch settings and their corresponding function.

Setting Number	DIP Switch Positions	Notes
0		"No Binding" mode
1		Channel 1
2		Channel 2
3		Channel 3
4		Channel 4
5		Channel 5
6		Channel 6
7		Channel 7
8		Channel 8
9		Channel 9
10		Channel 10
11		Channel 11
12		Channel 12
13		Channel 13
14		Channel 14
15		Channel 15

Legend





Configuration DIP switch settings and their corresponding function (continued).

Setting Number	DIP Switch Positions	Notes
16		Channel 16
17		Channel 17
18		Channel 18
19		Channel 19
20		Channel 20
21		Channel 21
22		Channel 22
23		Channel 23
24		Channel 24
25		Channel 25
26		Channel 26
27		Channel 27
28		Channel 28
29		Channel 29
30		Channel 30
31		"Bind Setup" mode



Legend

-  Switch is up
-  Switch is down